

Introduction

Purpose

- Provide an overview of the common mode choke series and an understanding of how they work.

Objectives

- Discuss the features and benefits of using common mode chokes

Content

- 19 pages

Learning time

- 20 minutes

Jul-10

Welcome to the Würth Elektronik Common Mode Chokes product training module. This module will discuss how to solve EMI issues with common mode chokes and the advantages of using them over other solutions.

Common Mode vs Differential mode

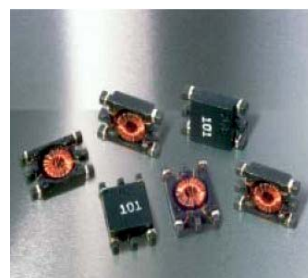
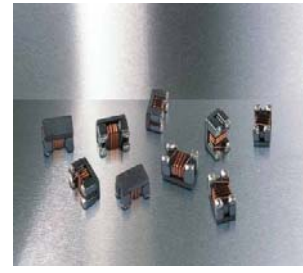
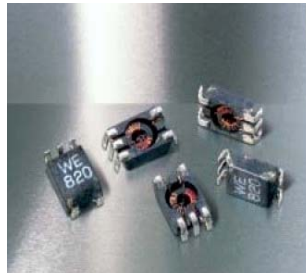
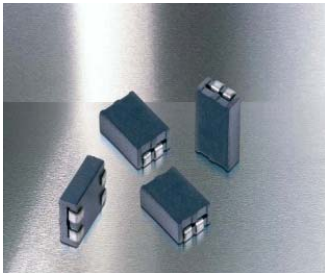

Jul-10

Understanding the difference between common mode signals and differential mode signals is extremely important as we need to know what the circuit requires to reduce noise.

How do we know if the noise is differential or common mode?

One way to test whether the problem is common mode or differential mode would be to attach a Würth Elektronik snap cable ferrite to the cable in question. By attaching the snap cable ferrite, we have to ensure that if there is an improvement in the reduction of noise, the problem is common mode. If not, then there is a differential problem. But keep in mind that in the cable are both wires included, towards and backwards the load.

Today we will discuss the common mode issues and focus on our surface mount product line.

Common mode chokes are used to reduce a specific type of electrical noise known as Common Mode Noise.

They are also referred to as Current Compensated chokes or Current Cancellation chokes.

Common mode chokes work well in applications like AC/DC power supplies (lines with large current flow) and signal lines, where distortion of the signal will create problems.

When it comes to AC power, common mode noise is the noise signal between the ground and neutral/phase. These tend to have higher frequency ranges than differential mode noise due to the fact that these originate from differential mode signals that are inductively or capacitive coupled.

Example: Flyback Converter

Formation of a differential mode interference current on the mains supply line of a flyback converter.

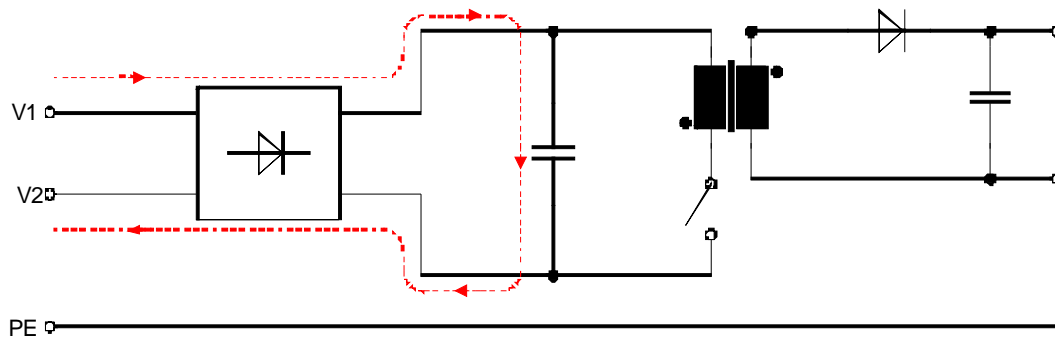

Würth Elektronik eiSos - 2009

Using the example above of a flyback converter, we can see the formation of a differential mode interference current on the supply lines.

We can see that the interference current is travelling in two different directions.

For the differential signal we can see that the current flows into the circuit (V1), through the load and back out (V2). The voltages on each wire are relative to ground potential. They do not travel through ground though.

For systems that are cable based, we are looking for this differential signal. This is the signal that will carry the data.

For differential mode signals, the voltage on V1 minus V2 equals the Differential Voltage.

Through a choke, this signal will create opposite, but equal, magnetic fields which will cancel each other out. The signal will pass through the choke unattenuated as it sees zero impedance created.

Example: Flyback Converter

Formation of a common mode interference current on the mains supply line of a flyback converter.

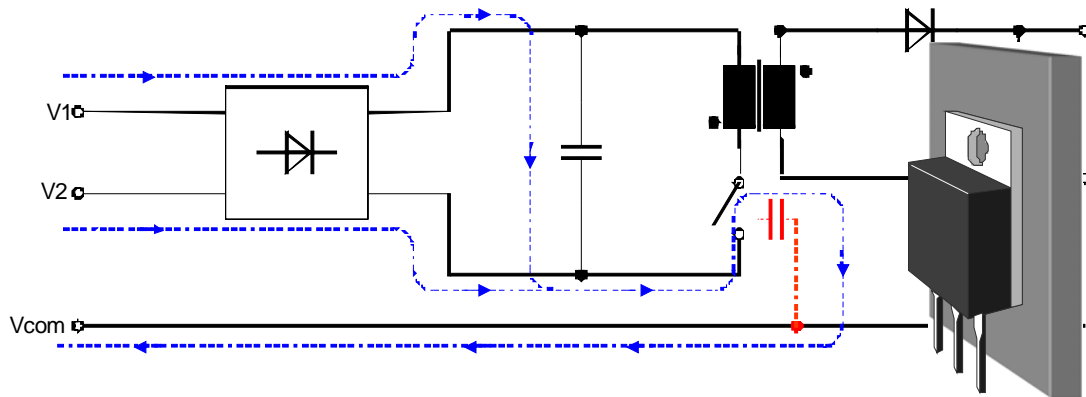

Würth Elektronik eiSos - 2009

In this situation, we see that the common mode interference current is travelling in the same direction into both paths of the circuit. There has to be a return path and this is usually through a ground plane or wire.

Here we see that there is a parasitic capacitance, creating a path for the common mode current to flow to ground. Current will not flow through the load as there is no potential difference across it.

The magnitudes of the signals are equal. These signals will add together instead of cancelling each other out.

The result will be a high impedance to the common mode signal which will become heavily attenuated. This potential will vary with respect to ground. As this varies from ground, radiation or noise will become present.

These signals are unwanted as they do not carry any data.

Using independent grounds can also create a difference in potential resulting in common mode noise.

This is very common as these can create ground loops.

This also occurs in ungrounded sources, such as remote ones.

Making sure that your cable for the analog signal is grounded well and having a properly grounded system can alleviate a lot of headaches. These can act as antennas if designed wrong.

Common Mode Chokes – Advantages



Filter using two chokes

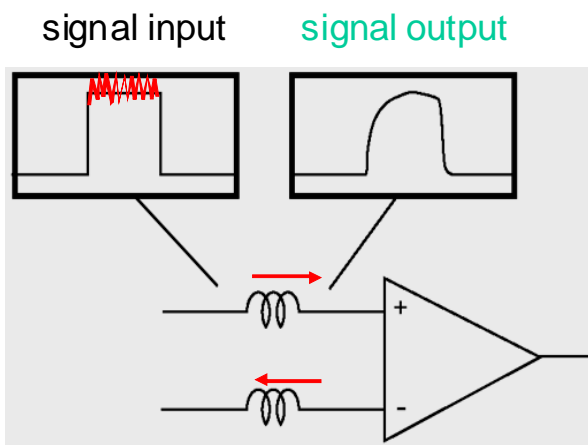

Filter using Common Mode Choke

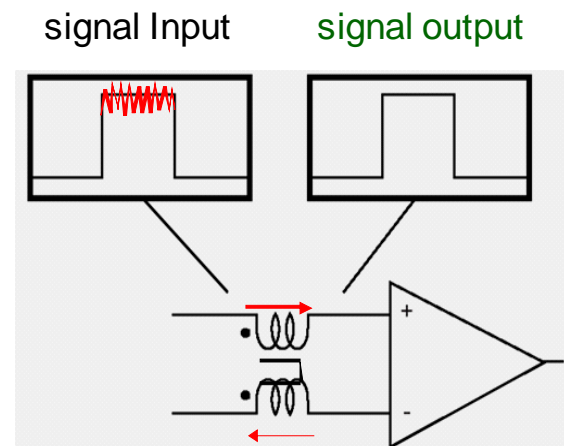

Würth Elektronik eiSos - 2009

Common mode chokes in series with these two paths can greatly reduce the noise without affecting the signal.

They work as a simple wire against differential currents and as an inductor against the common mode currents due to magnetic flux flowing inside the core of the ferrite.

Seen here in the first diagram, we can use two inductors or even chip bead ferrites to clip the noise. This will work in some applications where the output signal can be affected without creating problems. The signal output will be distorted on the rising and falling edges, because of cutting the needed harmonics for a square signal. Video applications and digital applications where sharp on and off times are needed will not appreciate this use of parts, otherwise the receiver is not able to detect the information in the signal.

Looking at the second diagram, we insert a common mode choke instead of two inductor or chip bead ferrites. The current on the desired signal path and the current on the electrical noise path will cancel out reducing the noise but leaving the signal intact.

Bifilar / Sectional Winding

Midcom



Sectional

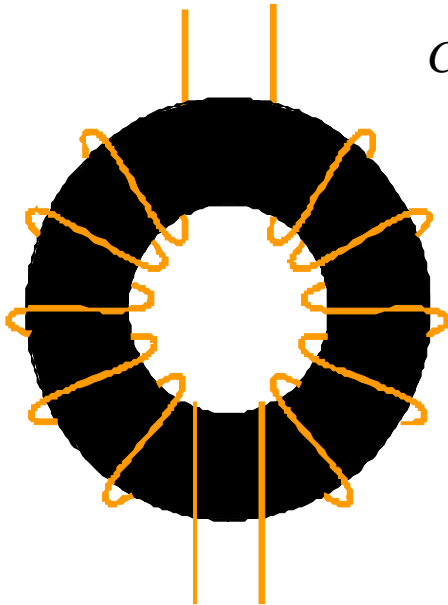

$$C = \varepsilon_0 \cdot \varepsilon_R \cdot \frac{A}{d}$$

Bifilar

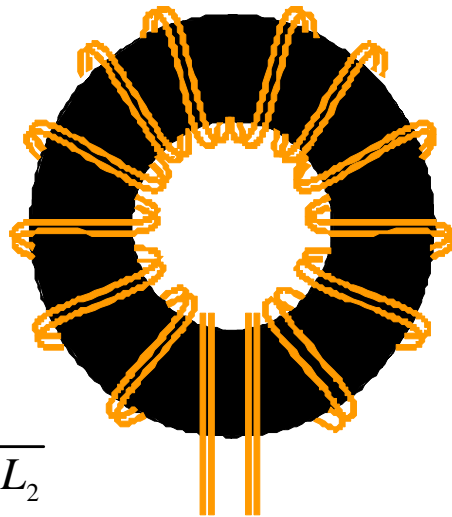

$$M = k \cdot \sqrt{L_1 \cdot L_2}$$

Würth Elektronik eiSos - 2009

There are two ways to wind the core for a common mode choke.

The first is using sectional windings. This is made up of two independent windings wound separate of each other.

The second would be the bifilar way of winding which incorporates two wires wound around the core together.

Bifilar windings do not improve differential mode impedance whereas Sectional windings will.

Würth Elektronik supplies common modes with both types of windings.

Bifilar Winding

Nidcom



Example: WE-SL2 744227
 Common Mode Impedance:

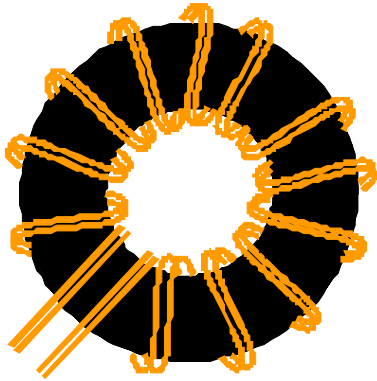

Differential Mode Impedance

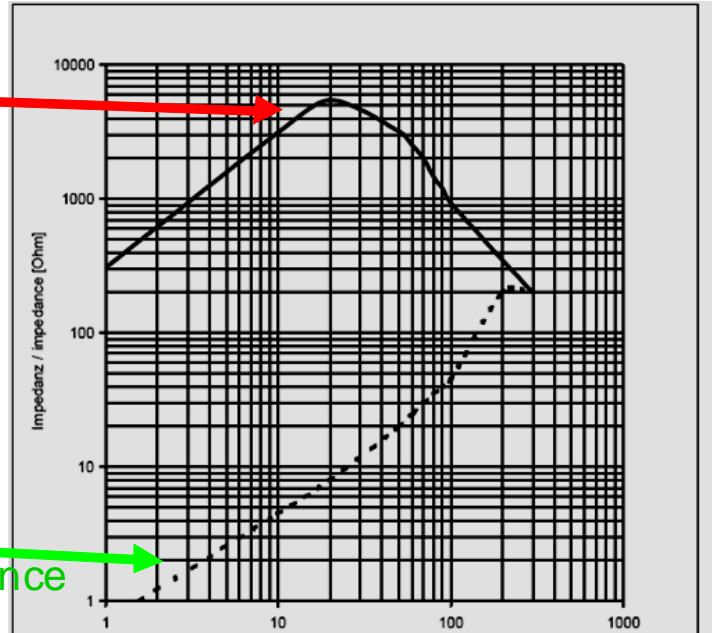

Würth Elektronik eiSos - 2009

The differential mode impedance is marked with the dotted line whereas the common mode impedance is the solid line.

Note that in a bifilar type winding, at 1 Megahertz, there is no impedance so any noise in that frequency range will not be attenuated.

If we run into an issue below that 1 megahertz range, we do have another solution.

Sectional Winding

Nidcom



Example: WE-SL2 744227S

Common Mode Impedance:

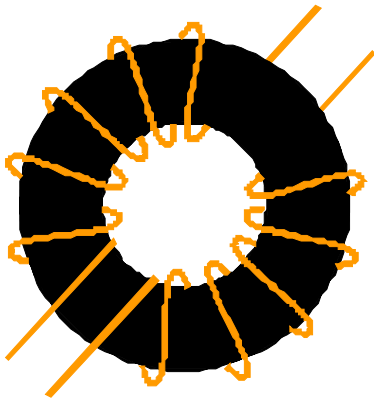

Differential Mode Impedance

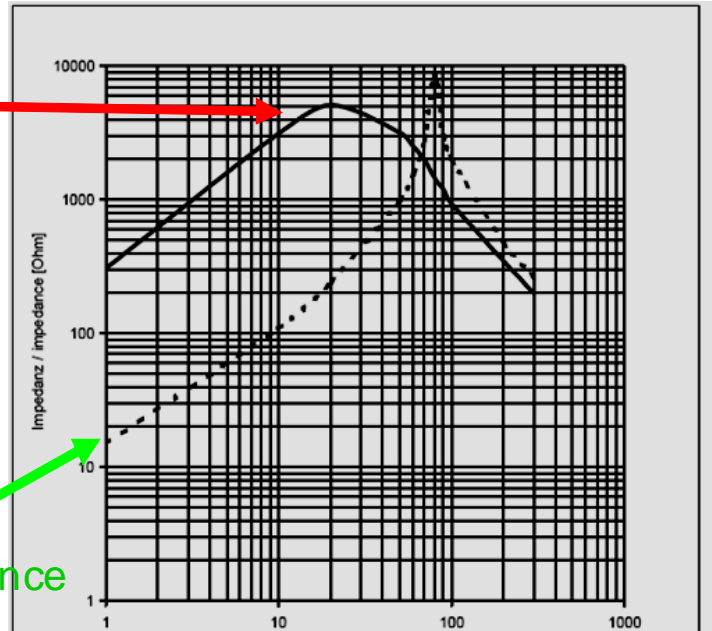

Würth Elektronik eiSos - 2009

By adding the sectional winding to the circuit, the differential mode impedance increases to the point where, at 1 Megahertz, there is over 10 ohms of impedance attenuating the lower frequency spectrum.

This increase is due to the leakage inductance that is induced between the separate windings. This acts in series with the load to provide differential noise filtering.

Data Line Common Mode Chokes

Data Lines – topologies:

- Bus Topology

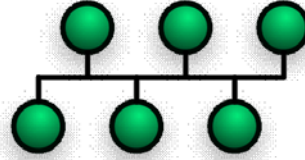

- Line Topology



- Ring Topology

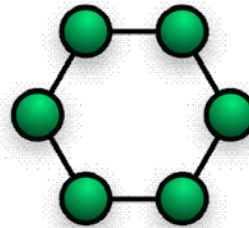

Würth Elektronik eiSos - 2009

Above are types of topologies used within the industry today. Bus Topology, Line topology and Ring topology. These are used to support USB, RS232, 485, firewire and other types of data lines.

The Bus topology is the most widely used as it supports board space requirements.

Data Line Common Mode Chokes



Data buses – topologies:

- Bus Topology
- USB:

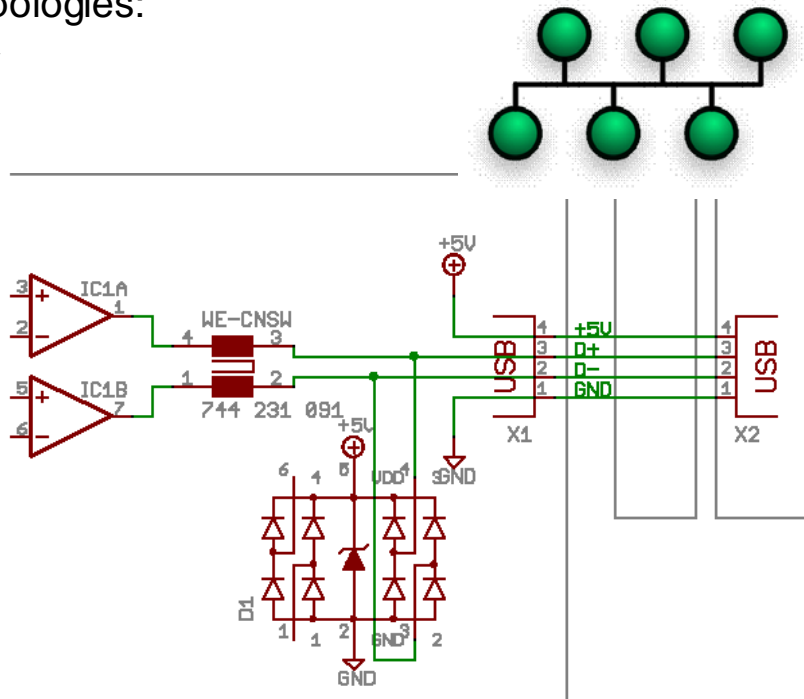

Würth Elektronik eiSos - 2009

Here we have inserted our WE-CNSW in series with the circuit D+ and D- lines to cancel the noise within the USB / Opamp circuit. We have also used a surge protection device, D1 in parallel with the lines for added surge protection from outside sources.

The common mode device here, since being put on the input line of the signal, will clean the signal just as it enters the circuit, preventing any other noise from being generated later on. It is also protected from surges by D1.

Common Mode Choke – Example: USB

Nidcom
Common Mode Choke

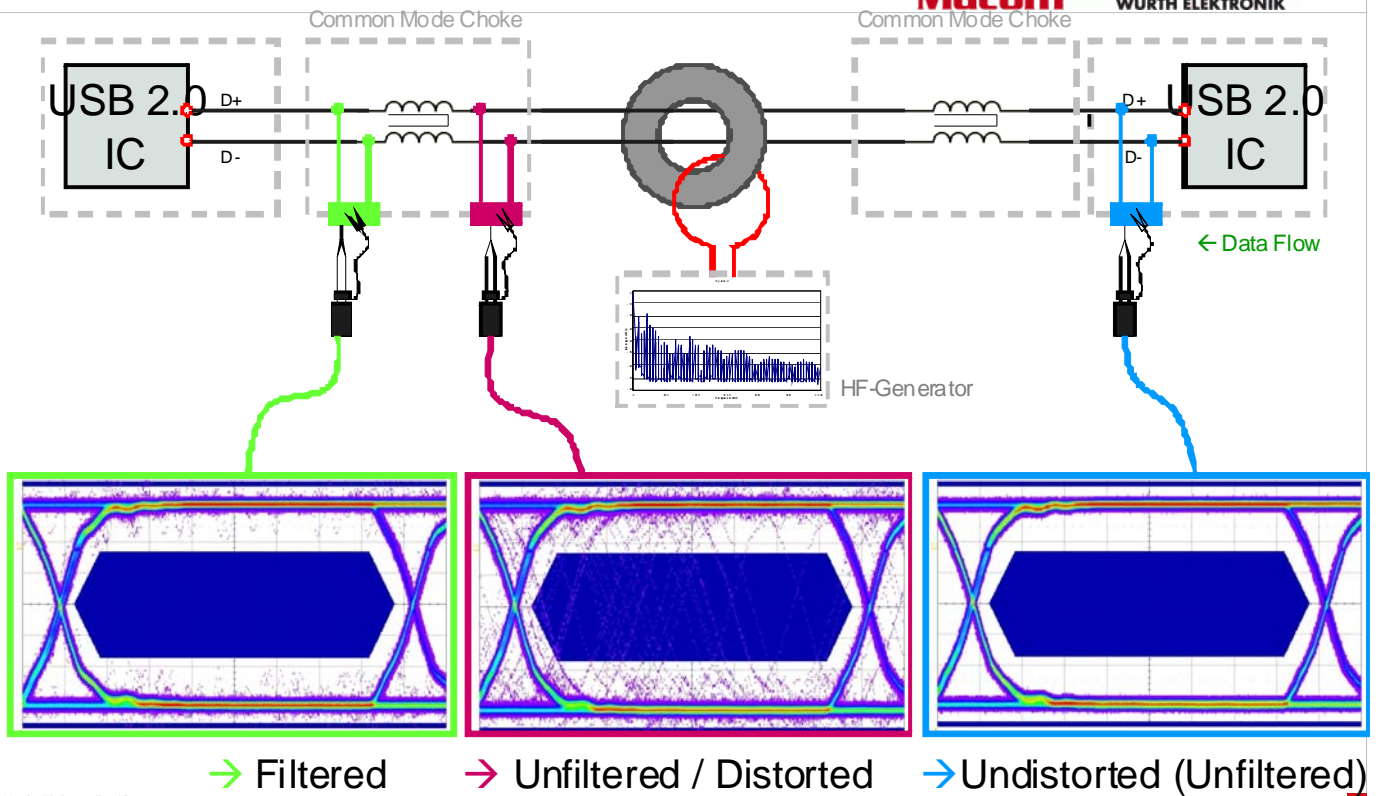

Würth Elektronik eiSos - 2009

When it comes to high resolution digital audio systems, this noise can induce errors as well as increase jitter in the recovered clock signal. They are also susceptible to ACI, Adjacent Channel Interference. Sharp on and off times can be critical. Here we are using voltage transition to represent timing information.

The main objective here is to transmit and recover data without errors. We also want to recover the clock with a minimal increase in Jitter. Per the SONET Specification, "Jitter is the short term variation of digital signals significant instants from their ideal positions in time".

Within this circuit board, there are ground planes, IC connections, and power supply planes that will have some inherent inductance, capacitance and resistance. These are parasitic impedances that common mode noise will migrate towards. These impedances and noise can also affect your clock and data in other parts of your circuit.

As mentioned before, planning a good strategy for grounding and combining power planes together, ground planes together, etc, can significantly improve performance. Keeping digital grounds tied together and separate from analog grounds (which are tied together) is an easy and nice solution.

Without getting into too much detail, we can see here that utilizing a common mode choke on the USB line, we can improve the noise, in turn improving the Jitter failure rate. Placing the common mode where the data enters the circuit (right hand side) will have the best effect as opposed to placing it later on in the circuit. Clean the signal as it comes in to prevent issues further on in the circuit.

The figure on the right would have the best placement of the common mode choke. Right on the input.

Common Mode Choke – Example: USB

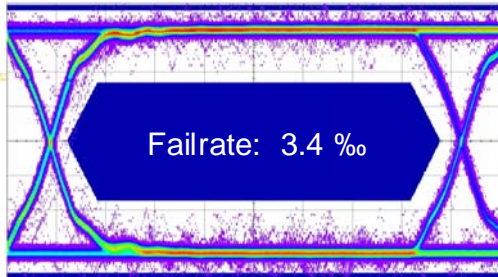

CM → 32 Ohm
DM → 0.7 Ohm @ 12 MHz

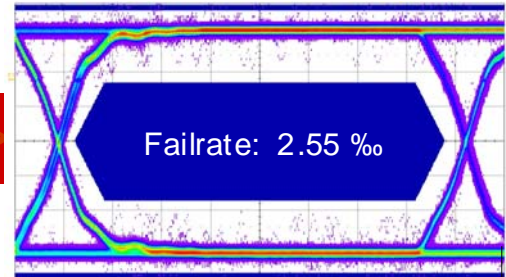
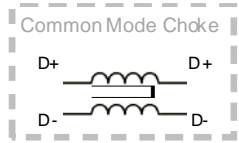

CM → 41 Ohm
DM → 0.7 Ohm @ 12 MHz

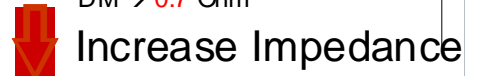

CM → 77 Ohm
DM → 1 Ohm @ 12 MHz

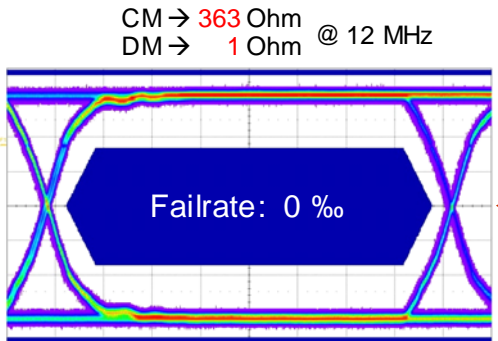

CM → 363 Ohm
DM → 1 Ohm @ 12 MHz

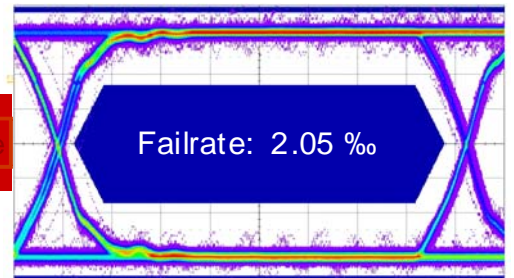

Failrate: 2.05 ‰

Würth Elektronik eiSos - 2009

Common mode noise voltage will always be present between the transmit and receive grounds. For this reason, some of the current will be flowing through the shield.

To further increase the performance, we need simply to increase the impedance of the device.

Here, we will start with the top left diagram, finishing at the bottom left diagram.

We have gone from a failure rate of 0.34% to 0% simply by increasing our impedance from 32 ohm on the common mode side and 0.7 ohms on the differential side to 363 ohms on the common mode side and 1 ohm on the differential side. This procedure was performed at 12 Megahertz using a common mode choke.

Chip Bead Ferrite – Example: USB

Nidcom

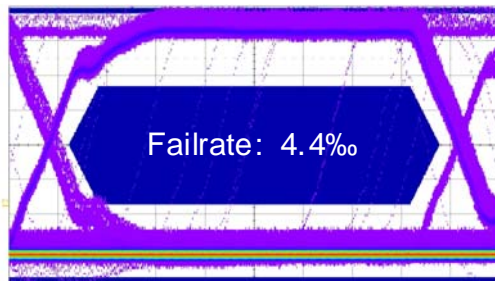

DM → 35 Ohm @ 12 MHz

Increasing Impedance

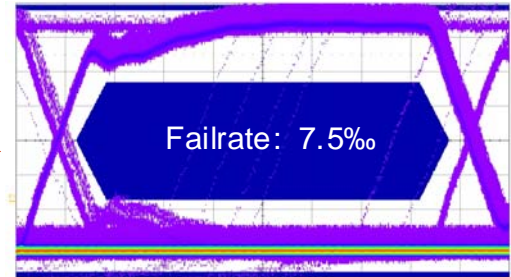
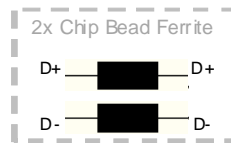

DM → 110 Ohm @ 12 MHz

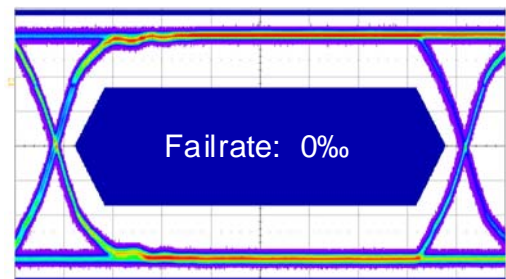

Würth Elektronik eiSos - 2009

We discussed being able to use inductors and chip beads in place of a common mode choke.

Here is an example where this could hurt us.

The inductor or chip bead ferrite will attenuate the noise as well as the signal and not cancel out the noise like the common mode choke would.

We started at a failure rate of 4.4% at 12 Megahertz.

We have increased the impedance (as we did previously with a common mode choke) but the resulting failure rate increased to 7.5%.

Notice on the 4.4% and 7.5% failure rate chart, the rising peaks of the eye have been distorted. They are not as sharp as they should be, per the 0% failure rate chart below.

Two independent filters like two inductors or ferrite beads have no magnetic coupling.

This is a result of the chip bead ferrites attenuating both the signal and the noise. Common mode chokes in this case would be the optimum solution, because of the magnetic coupling of both windings.

Data Line Common Mode Chokes

Midcom

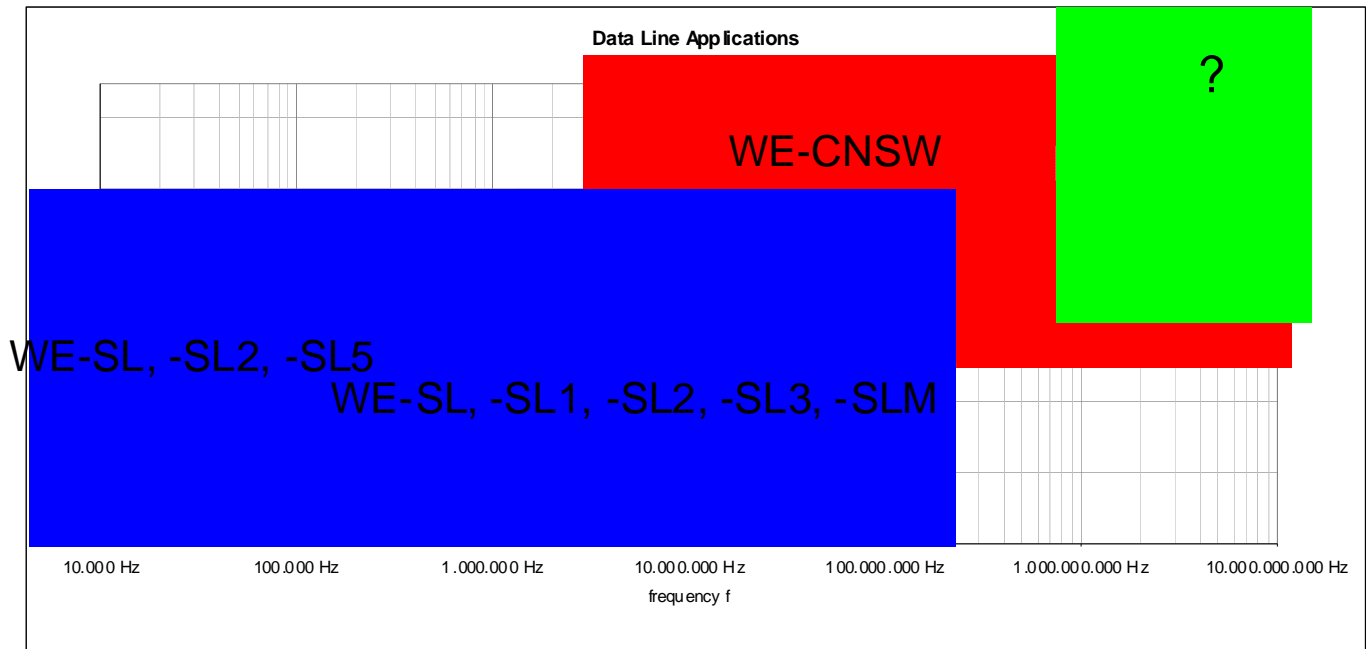

Würth Elektronik eiSos - 2009

Here we represent the frequency ranges in which the Wurth Electronics, Midcom common mode chokes operate.

Our WE-SL family of part as seen in blue operates from the lower frequency spectrum, 10 kilohertz, to the higher 10 megahertz side.

This is due to the Manganese Zinc and Nickel Zinc materials used.

These are targeted for DSL, Analog/modem applications, ISDN, CAN, Flexray, and Ethernet and USB applications.

For moving from USB and Ethernet into LVDS lines, SATA, DVI and HDMI, our WE-CNSW product family is optimum utilizing nickel zinc materials.

Common Mode Chokes (SMD)

Nidcom



WE-SL2 74422xx

for signal / data lines up to $I_{max} = 1,6 A$

MnZn	NiZn L ~ 25 μ H ... ~ 47 mH
------	---------------------------------



WE-SL3 74425xxx

for signal / data lines up to $I_{max} = 0,7 A$

NiZn L ~ 20 uH ~ 100uH



WE-SL5 74427xxxx

for signal / data lines up to $I_{max} = 2,5 A$

MnZn	L ~ 120 uH... ~ 4,7 mH
------	------------------------

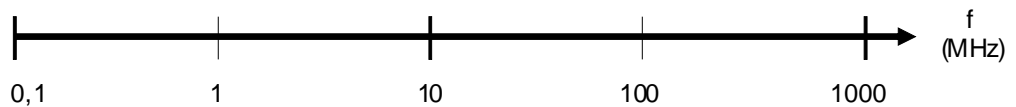

Würth Elektronik eiSos - 2009

To accurately select which common mode will support your needs, see the diagram here. We use Nickel Zinc for wideband and higher frequency applications and Manganese Zinc for lower bandwidth and frequency applications.

The SL family of parts supports data lines with typical currents ranging from 300 milliamps to 5.6 amps.

The WE-SL5 can handle currents to 2.5 amps but we have recently released two new WE-SL5 HC (high current) parts handling currents to 3.5 amps and 5 amps.

The WE-SL2 is the device that we discussed earlier utilizing either sectional or bifilar windings. These can handle up to 1.6 amps.

Common Mode Chokes (SMD)

Midcom

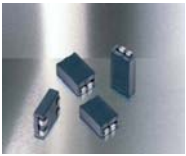

CM SMD-Ferrite 7427521

for signal / data lines up to $I_{\max} = 5 \text{ A}$

NiZn $Z = 52 \text{ Ohm @ } 100\text{MHz}$



WE-SL 74420x

for signal / data lines up to $I_{\max} = 5,6 \text{ A}$ order code 74420x

MnZn

NiZn $L \sim 10 \mu\text{H} \dots \sim 47\text{mH}$



WE-CNSW 74423xxxx

for signal / data lines up to $I_{\max} = 0,4 \text{ A}$ order code 74423xxxx

NiZn $Z = 67\text{--}2200 \text{ Ohm @ } 100 \text{ MHz}$

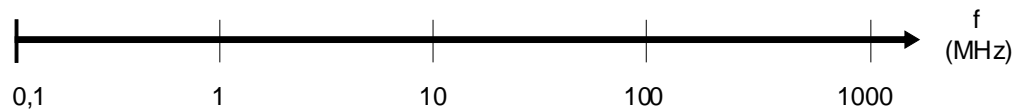

Würth Elektronik eiSos - 2009

The WE-SL has more pins supporting either 2 or 4 winding configurations

This can be used in applications like ISDN-Bus, measurement signal filtering as well as power supply systems lower than 80Vdc or 42Vac.

They can handle up to 5.6 amps of current.

The WE-CNSW comes in 0805 and 1206 packages. These have high common mode suppression at high frequencies, into the Gigabit range. Typical currents are 4 tenths of an amp.

Notice that the only part here using the manganese zinc material is the WE-SL. The rest of the parts utilize Nickel Zinc cores, supporting the higher frequency spectrum.

Offline Common Mode Chokes, WE-FC

Midcom



Characteristics:

Closed rectangular ferrite core
 2-section winding for excellent high frequency performance
 1% stray inductance for symmetrical interference suppression
 Recyclable due to no encapsulation
 2kV AC Isolation Voltage
 Operating temperature: -25°C up to $+125^{\circ}\text{C}$

Applications:

Switch mode power supplies
 Electronic ballasts for lamps

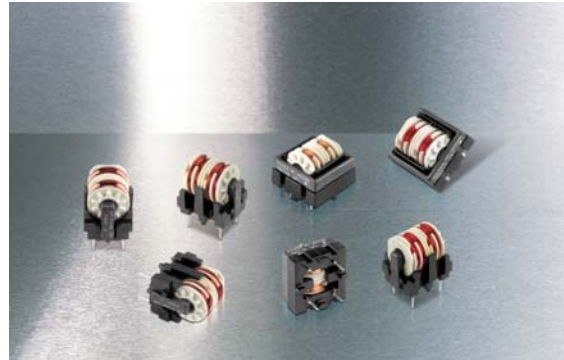

Specifications:

Rated for 250VAC
 Currents to 2A
 THT only
 Order Code 744864xxxx

Besides the offering of Common Mode Chokes for DC applications Würth Elektronik has also a large offering for offline applications.

The WE-FC is available in only through hole form.

It is optimal for high frequency performance.

With 2 kilovolt insulation between windings, current capability to 2 amps and rated for 120/240 volts AC, this part is suitable for Switched mode power supplies and lamp ballasts.

Temperature range is from -25 degrees Celsius to $+125$.

Offline CMC, WE-CMB

Midcom



Characteristics:

- Nickel-Zinc core
- High suppression rates of assymmetric interference @ high and medium frequencies
- Small size
- High interference stability against RF interference and burst signals
- Noise suppression up to 300 MHz

Applications:

- Power electronics
- Power line in- and output filter
- optimized for Burst signals

Specifications:

- Rated to 10A at 250VAC
- THT only
- 1.5KV Isolation

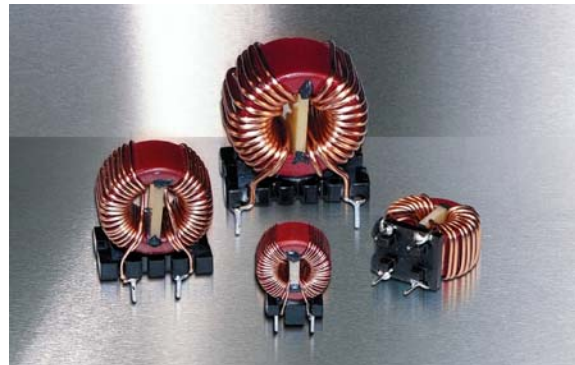

The WE-CMB common mode choke is also suitable for offline applications.

This comes in through hole form only.

Rated to 10 amps at 120/240 volts AC, it also has noise suppression up to 300 megahertz.

This is suitable for power line in and output filtering optimized for burst signals.

Common Mode Chokes

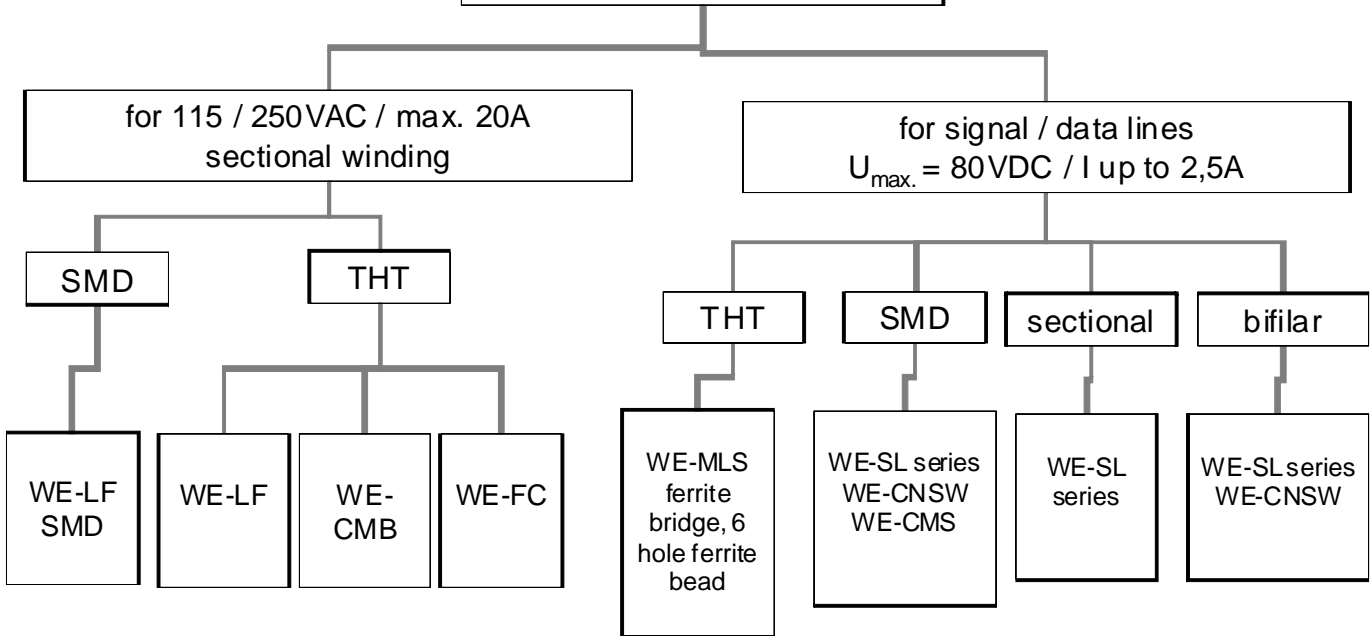

Würth Elektronik eiSos - 2009

In summary Würth Elektronik has a large offering on surface mount components for 80vdc max applications, but there is also an attractive offering on THT and SMD components for 110/220Vac applications.

Common Mode chokes internal to our RJ45's

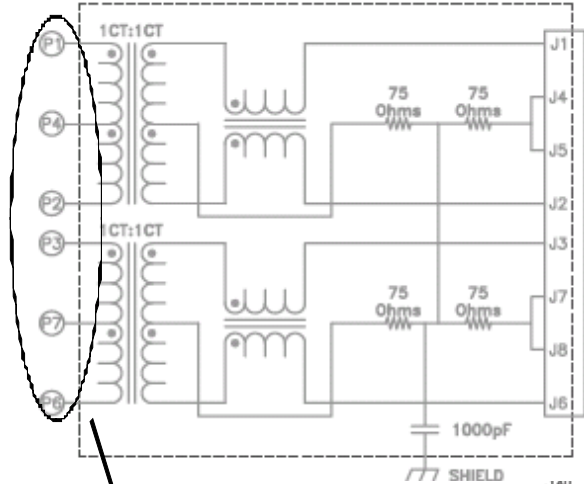

No common mode
In std RJ45

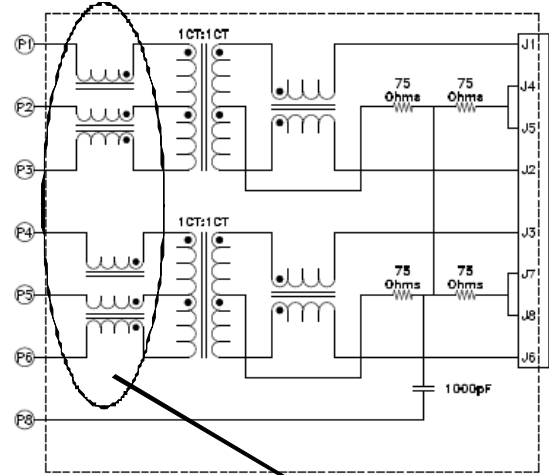
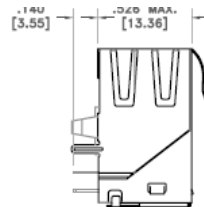
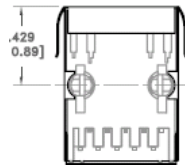

Common mode added
To HPLE series

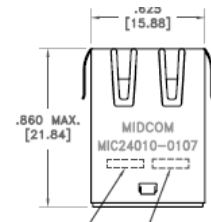

Würth Elektronik eiSos - 2009

Würth Elektronik has also included common modes on the PHY AND connector sides of one family of RJ45 Ethernet connectors.

The HPLE (High Performance Low EMI) family of connectors has an added a common mode choke on the connector side to solve the issue of clock harmonic noise further up the frequency spectrum.